

# ANNOUNCING VEEDER-ROOT'S NEW CARBON PRESSURE MANAGEMENT SYSTEM

## CARB APPROVED FOR ORVR-COMPATIBLE EVR SYSTEMS

With the Enhanced Vapor Recovery (EVR) Phase II deadline approaching, most California gasoline dispensing facilities must comply with new pressure management regulations before April 2009.

Veeder-Root has developed a pressure management solution that will allow end users to comply with these new regulations while minimizing the impact to their facility.

The Veeder-Root Carbon Pressure Management System reduces evaporative losses caused by over-pressurization and provides a cost-competitive alternative to current certified solutions.

This new pressure management system is designed to work with balance vapor recovery equipment. The innovative design provides for a quick, inexpensive installation that eliminates the need for expensive concrete pads, protective barriers, or AC wiring.

### How the system works

The Veeder-Root Carbon Pressure Management System mounts directly onto the station's existing vent riser, utilizing a single tap into the vapor space of the containment system. The canister contains activated 'high capacity' carbon that filters emissions that enter through an inlet at the bottom of the canister from the vent pipe.

The outlet at the top of the carbon canister releases cleansed air into the atmosphere reducing the pressure in the underground storage tank. The canister's operation is continuously monitored through an electronic control module that is interfaced to the TLS-350 via an intrinsically-safe electrical connection.

### When UST pressure goes positive:

- ⇒ The TLS-350 opens the valve on the output port of the canister allowing vapor to enter the canister.
- ⇒ As vapor flows through the canister, active carbon inside captures the hydrocarbon vapors allowing clean air to exit the canister, *reducing pressure in the UST.*

### When UST pressure goes negative:

- ⇒ The TLS-350 opens the valve on the output port of the canister allowing fresh air to enter the canister.
- ⇒ As the fresh air passes through the canister, the hydrocarbons are removed from the carbon and returned to the UST, *reducing evaporation.*

### System requirements:

- ⇒ Carbon Canister
- ⇒ TLS-350 Plus or TLS-350R with Version 29 software\*
- ⇒ Smart Sensor Module – 7 Channel

### Wireless option components: (Under CARB Evaluation)

- ⇒ Wireless Transmitter with Battery Pack
- ⇒ Wireless Receiver
- ⇒ TLS RF Wireless Interface Unit



### Features and Benefits:

- ⇒ Compatible with balance or front-end ORVR detecting EVR systems
- ⇒ Easy to install - attaches directly to the vent riser at any station
- ⇒ Requires a single 1/2" tap into the vapor riser pipe
- ⇒ Interfaces to the TLS-350 via a single 2-wire IS connection
- ⇒ Requires a single TLS Smart Sensor Module channel
- ⇒ Does not require a concrete pad or containment barrier
- ⇒ No AC power required
- ⇒ Low maintenance, no pumps or motors
- ⇒ Continuously monitored for proper operation and efficiency
- ⇒ Long service life
- ⇒ Low cost installation

### Carbon Canister Part Numbers and Descriptions

Part Number	Part Description
861290-002	Carbon Canister Vapor Polisher with 2" installation kit
861290-003	Carbon Canister Vapor Polisher with 3" installation kit

### Spare Parts

Part Number	Part Description
330020-643	Valve Enclosure Assembly
330020-644	Sensor Housing
330020-645	Filter
330020-638	Inlet Piping Kit
330020-647	Mounting Bracket Kit for 2" Vent Stacks
330020-648	Mounting Bracket Kit for 3" Vent Stacks

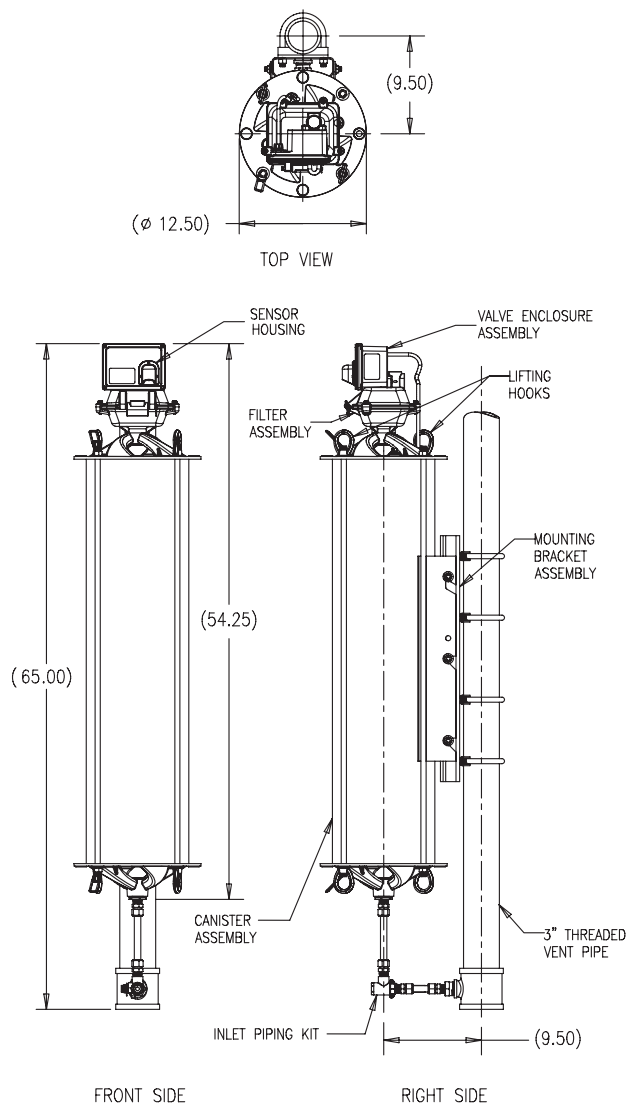

**Approximate weight of Carbon Canister: 70 lbs.**

\* This system is supported by the following consoles:  
 TLS-350 • TLS-350 Plus • TLS-350R • Red Jacket ProMax • Gilbarco EMC • Simplicity



For more information on the Carbon Pressure Management System, please visit [www.veeder.com/page/EVR\\_Solutions](http://www.veeder.com/page/EVR_Solutions)