



# INSTALLATION INSTRUCTIONS

## VACUUM BREAKER

Part No. 123-039-5

The following defined terms are used throughout this literature to bring attention to the presence of hazards of various risk levels, or to important information concerning the life of the product.

**DANGER**

indicates presence of a hazard which *will* cause *severe* personal injury, death or substantial property damage if ignored.

**WARNING**

indicates presence of a hazard which *can* cause *severe* personal injury, death or substantial property damage if ignored.

**CAUTION**

indicates presence of a hazard which *will* or *can* cause *minor* personal injury, death or substantial property damage if ignored.

**NOTICE**

indicates special instructions on installations, operation, or maintenance which are important but not related to personal injury hazards.

The Vacuum Breaker was designed to eliminate a vacuum from occurring in a product line. Red Jacket discovered a vacuum was being created in the product lines during extreme thermal contraction periods. When a mechanical leak detector has been exposed to a vacuum its opening time is increased dramatically.

**WHEN TO USE:** If a station is experiencing restricted flow due to the mechanical leak detector tripping, in the mornings or between product dispensing, installing a Vacuum Breaker may solve the problem.

**NOTICE**

**This instruction sheet should be kept with the end user of the vacuum breaker for reference.**

**WARNING**

**Tampering with the screws or seal on this vacuum breaker may inhibit operation and will void warranty.**

**DANGER**

**Disconnect power to the submersible pump when installing or removing gas pressurization equipment.**

1. Disconnect power to the pump at the load center.

**WARNING**

**Tag or lock out the breaker to avoid the pump being turned on accidentally.**

2. Loosen the line test 1/4-inch NPT pipe plug located on the top of the packer assembly to relieve any pressure in the line.
3. Remove the 1/2 inch hex head cap screw (pac/man lockdown bolt) adjacent to the manifold tank 1/4 inch NPT pipe plug. Refer to Figure 1.
4. Remove the line test plug and tank 1/4 inch NPT pipe plug located on top of the packer.

- a. If using in conjunction with an FX1, FX1D, XLD or DLD leak detector, apply U.L. classified non-toxic pipe thread sealant to the 1/4 NPT threads on two straight tube fittings and install into the two 1/4 NPT openings in the packer (line test and tank), see figure 1.

If using in conjunction with an FX1V, FX1DV, FX2V, FX2DV, FX2, FX2D, PLD or XLP apply U.L. classified non-toxic pipe thread sealant to the threads on one straight tube fitting and one 45 degree street elbow. Install straight fitting to 1/4 inch line test opening in Packer and install 45 degree street elbow to 1/4 inch tank test opening in the Packer. Apply U.L. classified non-toxic pipe thread sealant to both ends of 1/4 inch hex nipple. Install hex nipple into 45-degree street elbow. Install female tee on hex nipple. To proceed with installation, find paragraph referring to the leak detector model that applies to your situation.

**FX1V, FX1DV, PLD or XLP**

Apply U.L. classified non-toxic pipe thread sealant to the threads on two 90-degree elbows. Install elbows into remaining openings of female tee, see figure 2.

**FX2 or FX2D**

Apply U.L. classified non-toxic pipe thread sealant to the threads on one 90-degree elbow and install on the side of the female tee. Apply U.L. classified non-toxic pipe thread sealant to the 1/4-inch NPT threads of one Snap Tap and install into remaining opening of female tee, see figure 3.

**FX2V or FX2DV** (If remaining fittings consist of second hex nipple and second female tee)

Apply U.L. classified non-toxic pipe thread sealant to the 1/4-inch NPT threads on second hex nipple. Install second hex nipple into top open-

ing of the previously installed female tee. Install second female tee on second hex nipple. Apply U.L. classified non-toxic pipe thread sealant to the threads on two 90-degree elbows. Install elbows into sides of the female tees. Apply U.L. classified non-toxic pipe thread sealant to the 1/4-inch NPT threads of one Snap Tap and install into remaining opening of second female tee, see figure 4.

**FX2V or FX2DV (If remaining fittings consist of street tee alone)**

Apply U.L. classified non-toxic pipe thread sealant to the 1/4-inch NPT threads on street tee. Install street tee into top opening of the female tee. Apply U.L. classified non-toxic pipe thread sealant to the threads on two 90-degree elbows. Install elbows into sides of the female tee and the street tee. Apply U.L. classified non-toxic pipe- thread sealant to the 1/4 NPT threads of one Snap Tap and install into remaining opening of street tee, see figure 4.

5. Mount the vacuum breaker (eliminator) using the 1/2 inch, 13 x 1-1/2 hex head cap screw supplied with the assembly. Reference Figure 1.
6. To install tubing if using in conjunction with an FX1, FX1D, XLD or DLD:
  - a. Apply U.L. classified non-toxic pipe thread sealant to the threads of two 90-degree tube fittings and install into the two tapped openings in the Vacuum Breaker cap.
  - b. Install tubing as shown in figure 1.
  - c. Tighten as shown in instructions supplied with the fittings.
7. To install tubing if using in conjunction with an FX1V, FX1DV, FX2, FX2D, FX2V, FX2DV, XLP or PLD:
  - a. Apply U.L. classified non-toxic pipe thread sealant to the threads on two straight tube fittings and install into the two tapped openings in the Vacuum Breaker cap.
  - b. If using in conjunction with a FX1V, FX1DV, XLP or PLD leak detector, install tubing as shown in figure 2.
  - If using in conjunction with a FX2 or FX2D leak detector, install tubing as shown in figure 3.
  - If using in conjunction with a FX2V or FX2DV leak detector, install tubing as shown in figure 4.
  - c. Tighten as shown in instructions supplied with the fittings.

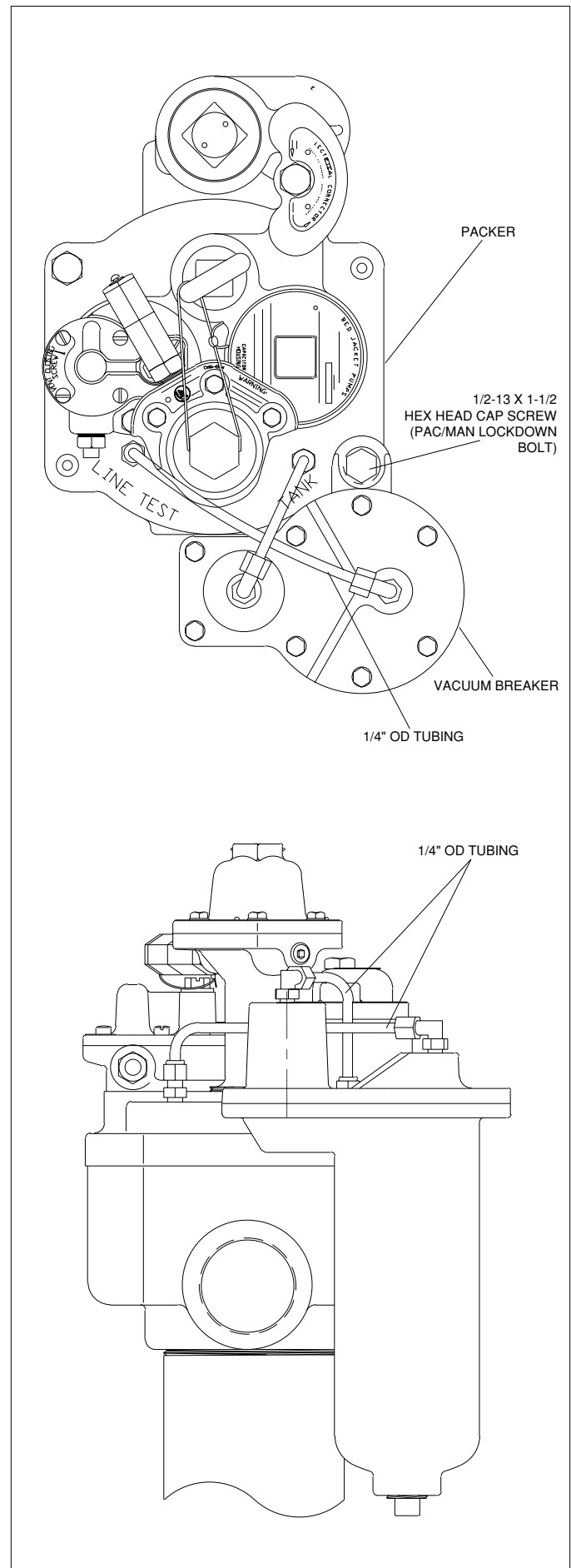

Figure 1

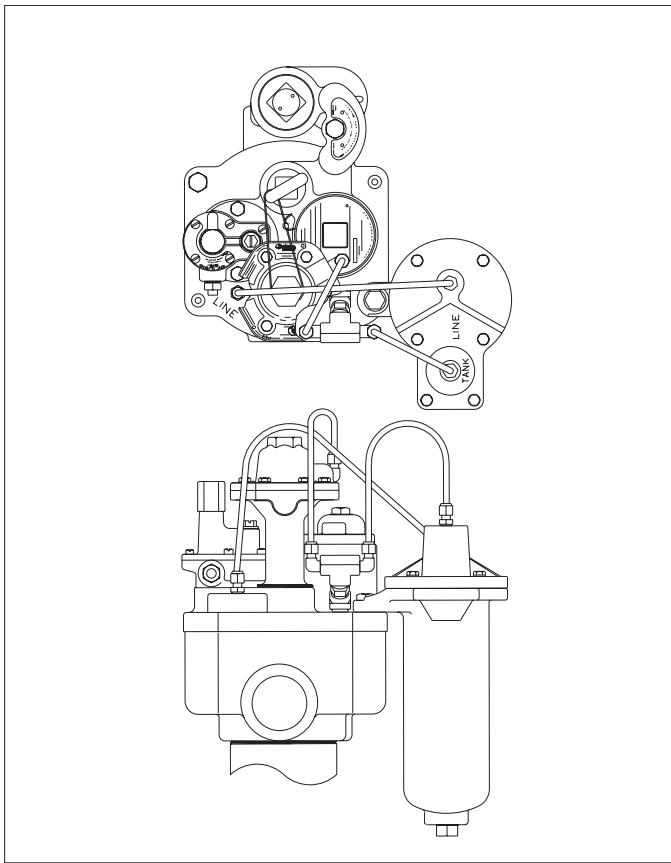

Figure 2

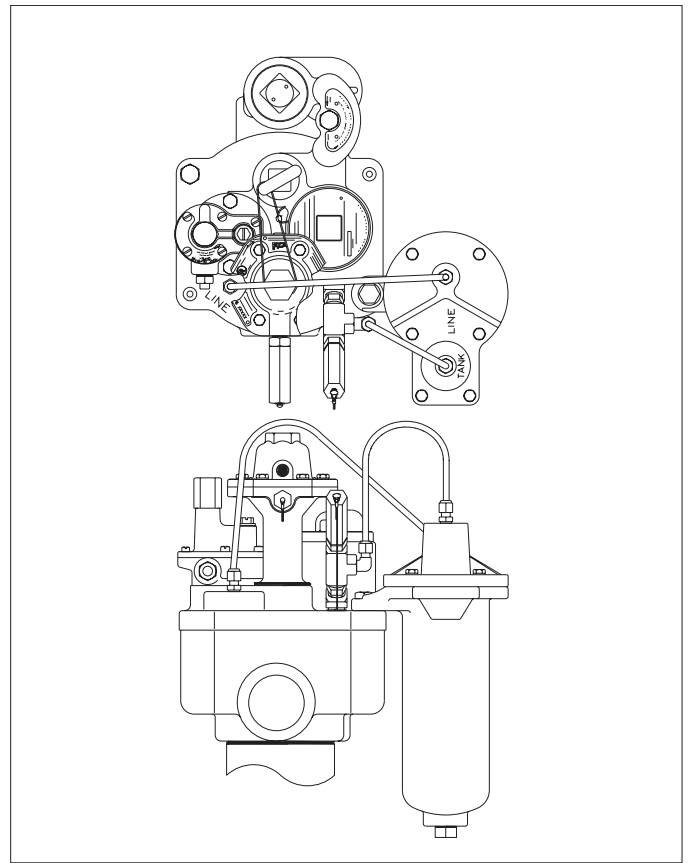

Figure 3

**WARNING**

**Do not over tighten the fittings yet. Do make sure all fittings are tight enough to prevent possible leaks into the ground and/or water seepage inside the leak detector and tank. Check tubing and fitting joints for kinks and damage after installation and periodically thereafter. This should be done at least annually and can be performed with the annual leak detector functionality check.**

8. Connect power to the pump at the load center.
9. Clear remaining air from the system as follows:
  - a. Turn on the dispenser that is farthest from the packer but do not open the nozzle. Wait at least four minutes. Look for leaks around all parts serviced.
  - b. Shut off the pump and allow it to stand idle for four to five minutes. Start the pump again and repeat as above.

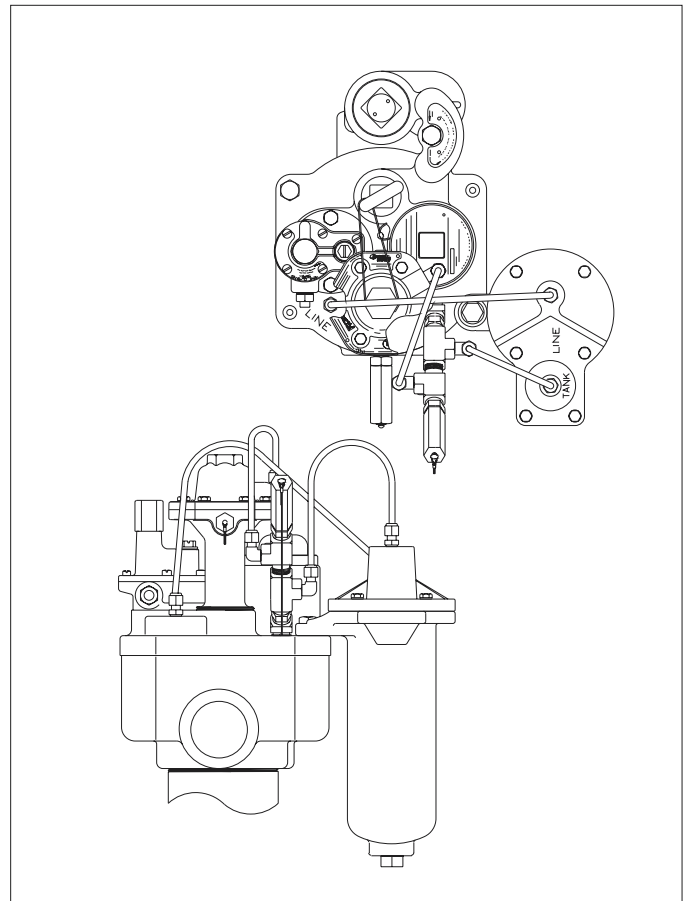

Figure 4



by  **VEEDER-ROOT**

125 Powder Forest Drive • Simsbury, CT 06070  
Tel: (860) 651-2700 • Fax: (860) 651-2719