

# ST Quick Reference Guide

## ALARM SITUATIONS



If the ST sounds an alarm, stay calm and follow these steps:

- Wait until printer stops printing alarm report.
- Press **(E)** to silence alarm.
- Follow your company guidelines.

### NOTICE

It is very important that each company have a set of Alarm Procedure Guidelines and that every employee is familiar with these procedures. Please attach a copy of your guidelines to this Quick Reference Guide.

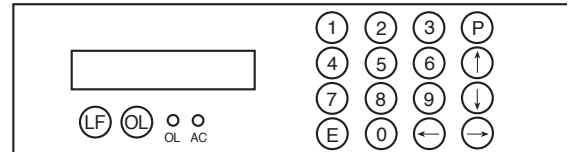

## IN CASE OF EMERGENCY CALL:

## PRINTER PAPER

### CHANGING PAPER

- Press the **(OL)** button to take printer off-line.
- Open the top cover by tilting up and back.
- With scissors, cut a straight edge across a new roll of Red Jacket printer paper.
- Place new roll on spindle and into unit *feeding from the bottom of the roll.*
- Feed paper into slot above printer head.
- Press the **(LF)** button to advance paper. Advance until the strip is long enough to feed through the slot in the ST's cover.
- Feed paper strip through slot and close the ST's cover.
- Press the **(OL)** button to put the printer back on-line.

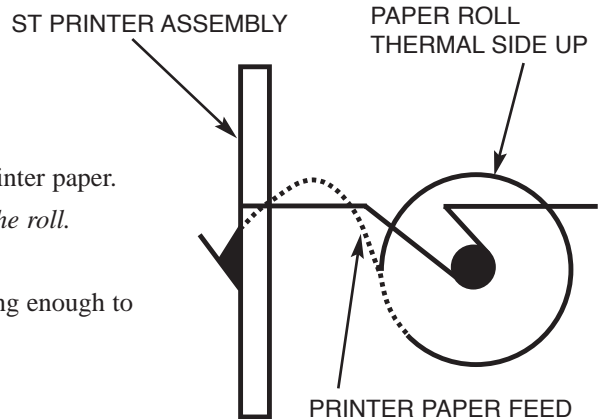

### CLEAR PAPER JAM/RESETTING PRINTER

Occasionally the ST's printer will jam. If this happens, follow these steps:

- Open the top cover by tilting up and back.
- Clear the paper jam and straighten the paper's edge.
- Press the red RESET button.
- Use the **(LF)** button to feed paper up and through the ST's top cover.
- Close cover and press **(OL)** to put the printer back on-line.

## CURRENT STATUS

You can view the current conditions monitored by the ST by pressing the following keys:

- 1 Product Height
- 2 Gross Volume (for Net Volume press **(↓)** key)
- 3 Ullage
- 4 Water Height
- 5 Product Temperature

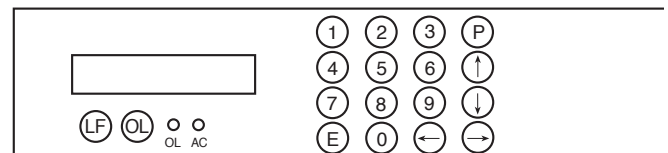

Use the up **(↑)** or down **(↓)** arrow keys to scroll through individual tanks.

# REQUEST REPORT



## GENERAL INFORMATION

The ST is constantly monitoring these five things:

- Product Height
- Gross Volume
- Ullage
- Water Height
- Product Temperature

Each of these categories can be printed out individually, but it's easier to get all five at once. Anytime you need any or all of this information just press the **(P)** key from SELECT DISPLAY\* and a complete report will print out.

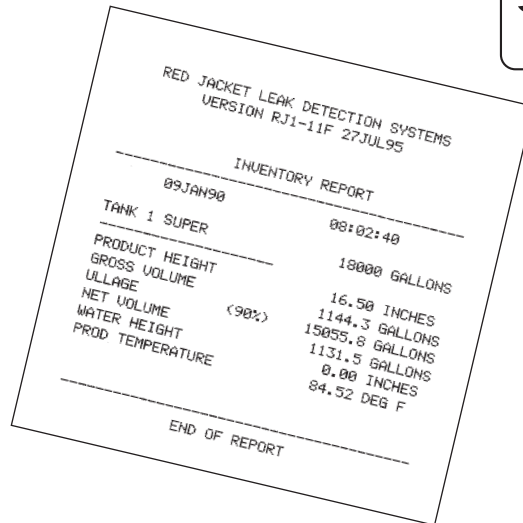

## PRINT MENU

- Begin at SELECT DISPLAY.\*
- Press **(→)** key.
- Press **(↑)** key to select Print Menu Items.
- Press **(P)** key.
- Press **(↑)** key to select Tank.
- Press **(P)** key.



**Print Menu Items**

Inventory	Leak Summary
Product Height	Tank Chart
Gross Volume	System Program
Net Volume	Diagnostic
Water Height	Auto Calibration
Product Temperature	Last Pass Test
Ullage	

## CHRONOLOGICAL HISTORY

This report option allows you to pull history reports from a specified time frame. (For instance, all leak tests between time A and time B.) To print a chronological history report:

- Begin at SELECT DISPLAY.\*
- Press the **(6)** key; History Chronological appears on display.
- Use right **(→)** arrow key to locate desired report category.
- Press **(P)** key; "Start Printing" appears on display.
- Enter day/month/year and time for beginning of time frame desired. (Use arrow keys to move around.)
- Press **(E)** key; "End Printing at" appears on display.
- Enter day/month/year and time for end of time frame desired. (Use arrow keys to move around.)
- Press **(E)** key and ST begins printing requested report.



**Report History Items**

- Product Height
- Gross Volume
- Net Volume
- Water Height
- Product Temperature
- Product Dispensed
- Reconciliation
- Leak Detection and more!

\* If display reads other than "Select Display", press the **(E)** key until "Select Display" appears.